

**DESIGNED with
MAXIMUM FLEXIBILITY**

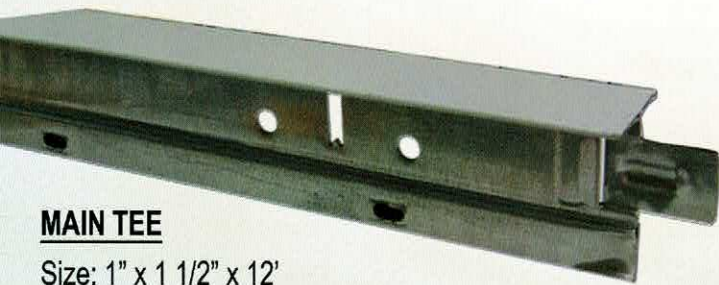

MAIN TEE

Size: 1" x 1 1/2" x 12'

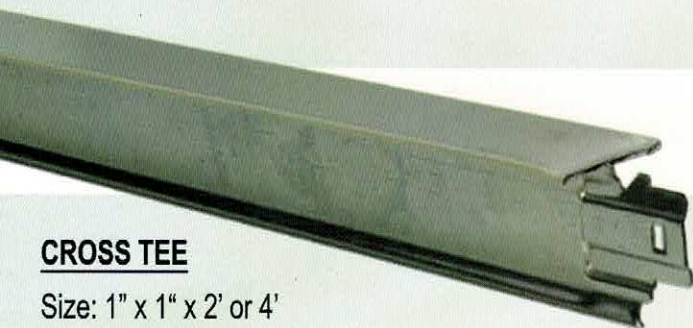

CROSS TEE

Size: 1" x 1" x 2' or 4'

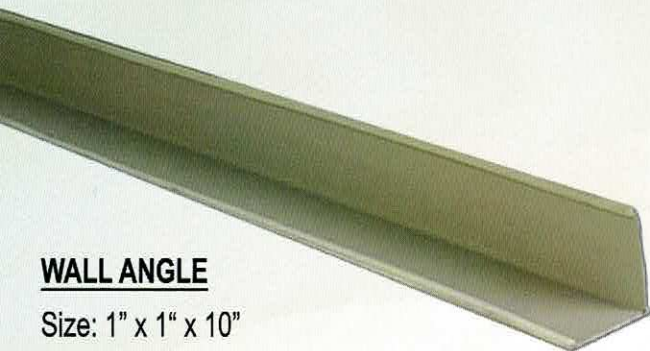

WALL ANGLE

Size: 1" x 1" x 10"

OPTIMUM ADVANTAGE from a
WORLD CLASS TECHNOLOGY

Oven - baked tile - white finish

Straight push-in joinery with "stepped edge"
for a clean main & cross tee intersection

Interlocking system engineered for fire
protection

Hanger holes engineered for installation
flexibility

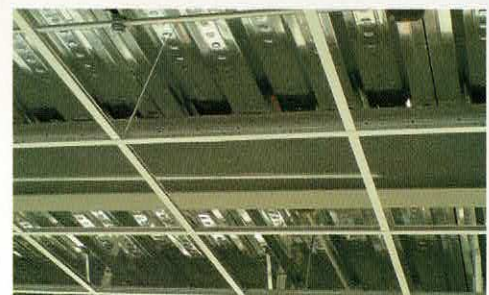
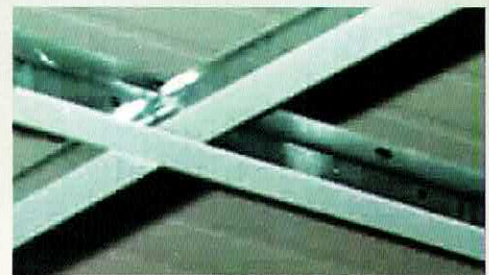



CMT[®]

Suspended Ceiling System

Installation Guide

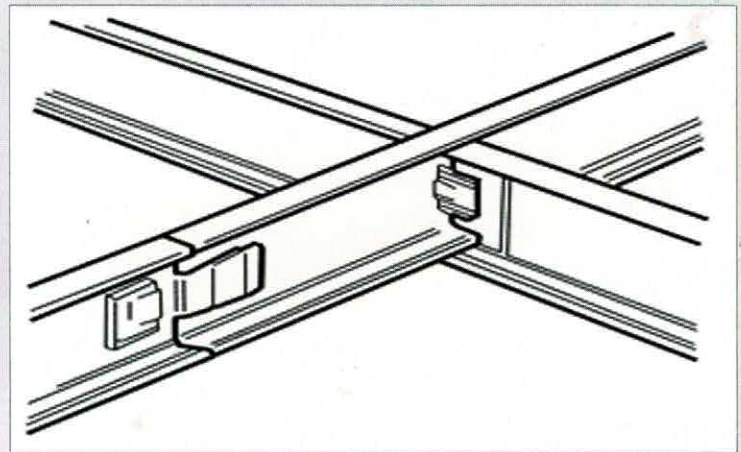
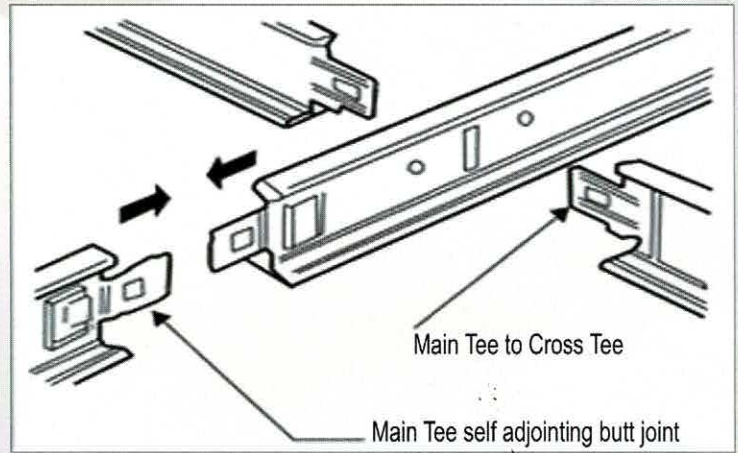
1. Level the ceiling height by the use of a water level or laser beam.
2. Wall angles to be installed using screws, stub nails or drywall fasteners depending on the wall type.
3. The ceiling is to be set out from the center to balance the width of the boards at the perimeter. Center to center distance for main runners and cross tees at 2 ft x 2 ft or 2 ft x 4 ft.
4. Maximum distance from wall to first hanger is 2 ft.
5. Main runners are joined together by inserting a tab on the end of one section into a slot in the adjoining section.
6. Cross tees are inserted in slots in the main runners and locked in position with minimal downward force.
7. When all sections have been installed, adjustment can be made to ensure that the whole suspension is leveled.
8. Ceiling boards are then laid on the grid.
9. Make sure all ceiling boards are carefully arranged.



PRODUCT	LENGTH	QTY/CTN	GROSS WT/CTN
 MAIN TEE	12 FEET	25	32 Kg.
 CROSS TEE	2 FEET 4 FEET	75 50	13 Kg. 18 Kg.
 WALL ANGLE	10 FEET	40	26 Kg.

Item Code: 13040

